

Single-stage volute casing pump

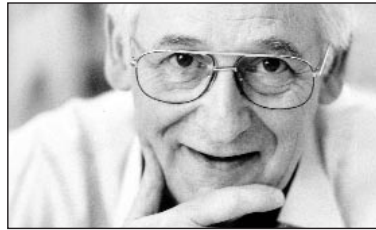

People at KSB – We make your world flow round

SPY – THE ALLROUND PUMP FOR HIGH FLOW RATES

The higher the demands placed on the flow rates of a pump, the greater the part that play factors such as operational reliability and service friendliness as well energy-saving operation of a pump. KSB has incorporated all its long experience in pump manufacture and plant construction in the development of the SPY series. The SPY series impresses by its low life cycle costs (LCC). Above all its optimized hydraulic system with low energy consumption, long service intervals, and the use of

standard spare parts are of value. Amply dimensioned shaft and bearings make for smooth operation and consequent low loading of the entire pump. Downtimes for maintenance can be kept short thanks to a well-conceived back pull-out design. Quality assurance according to international standards and more than 1,400 KSB service specialists all over the world guarantee utmost reliability and operating capability of our pumps. Find out more about our products at www.ksb.com/productcatalogue.



SPY

Single-stage
volute casing pump



Reduced susceptance to failure

No ancillary systems

Low life cycle costs (LCC)

Low energy consumption, long service intervals and standard spare parts

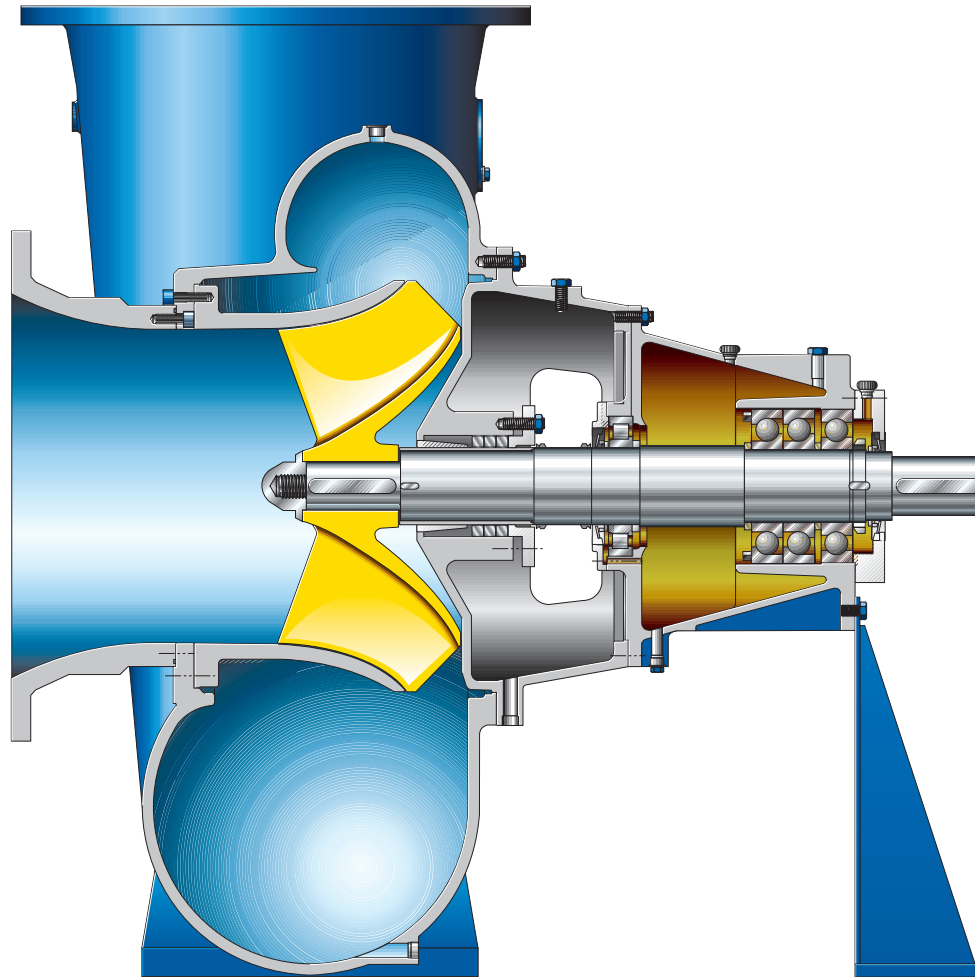

Smooth and reliable operation

Compact bearing bracket and thick shaft, low NPSH

Quick replacement and maintenance

Back pull-out design, roller bearings and replaceable wear rings

Applications:

- Irrigation
- Drainage
- Water supply
- Condensate transport
- Cooling water supply
- Waste water handling
- Etc.

Technical Data:

Size:	DN 350 up to 1,200
Flow rate:	from 500 up to 21,600 m ³ /h from 2,201 up to 95,102 US gpm
Head:	from 5 up to 50 m from 16 up to 164 ft
Discharge pressure:	up to 10 bar up to 145 psi
Temperature:	up to +105 °C
Speed:	1,480 min ⁻¹

Further information: www.ksb.com/productcatalogue