

OUR BEST ARGUMENTS ARE MAGNETIC.

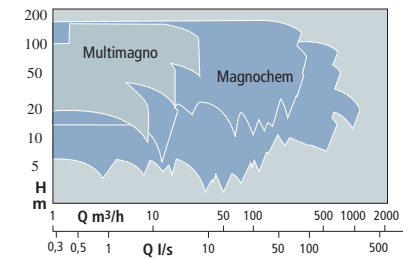

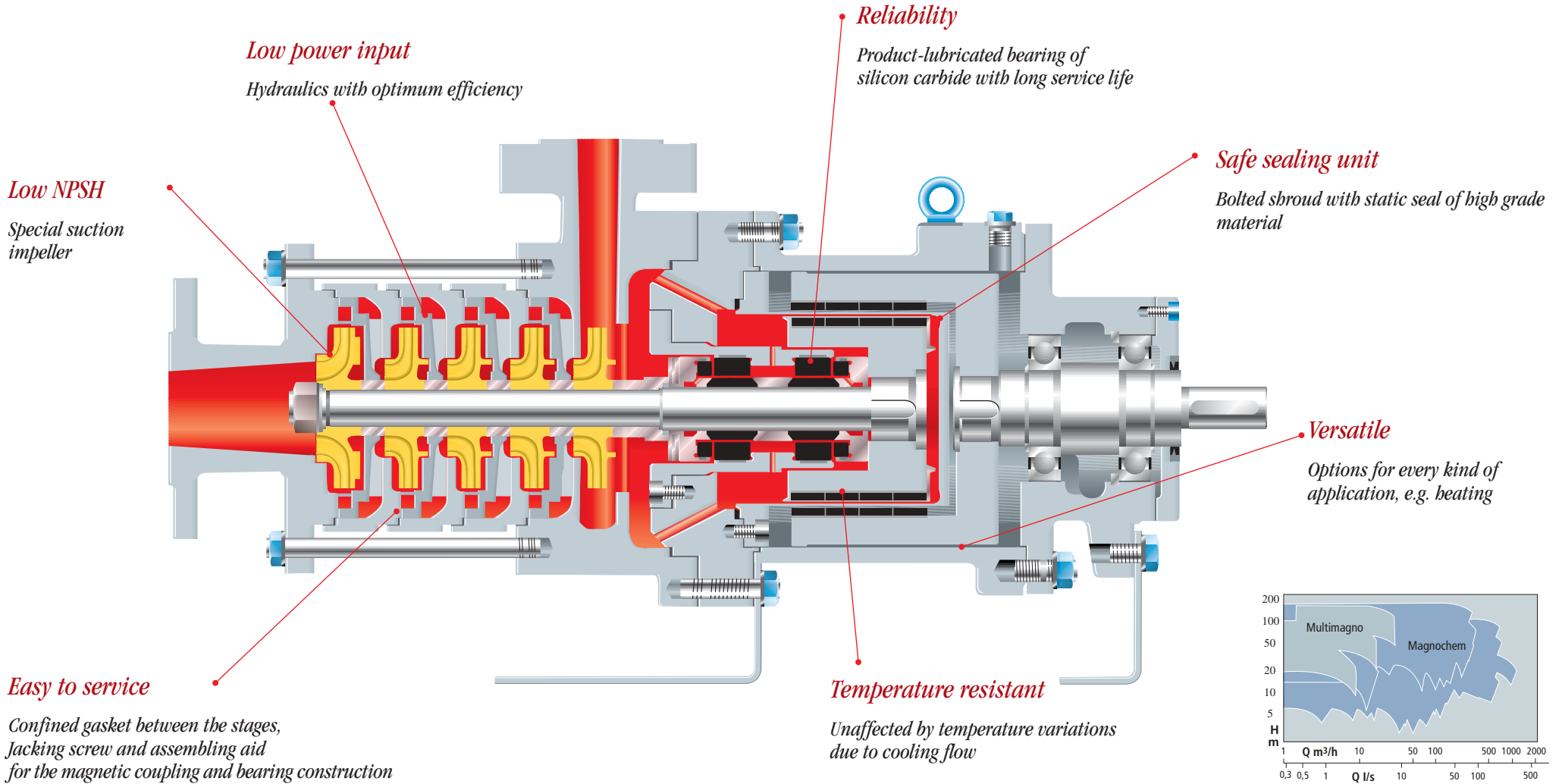

# Multimagno



## Multimagno

### The range of the Magnochem

Q:	up to 1200 m <sup>3</sup> /h	Material:	
H:	up to 150 m	EN-JS 1025 (GGG 40.3),	
t:	-40 to +300 °C	GP240GH+N (GS-C25N),	
p:	PN 16, PN 25	1.4408, 9.4460, specialist materials	

### The range of the Multimagno

Q:	up to 30 m <sup>3</sup> /h	Material:	
H:	up to 150 m	EN-JS 1025 (GGG 40.3)	
t:	-40 to +250 °C	1.4408	
p:	PN 25		



# M a g n o c h e m



With the Magnochem a new product range comprising innovative pump technology is presented which offers mature, cost-saving and environmentally sound solutions for a large field of applications.

## Safety

only two static seals

## Diversity

heatable casing  
different materials available

A sealless pump such as the single stage Magnochem is an investment in the future, both from an ecological and economical point of view. A future that has already begun.

For this reason, a conversion kit is available in addition to the new pump which converts any KSB standardised chemical pump into a Magnochem.

The adaptation can be made quickly and simply by your site technicians without much expenditure.

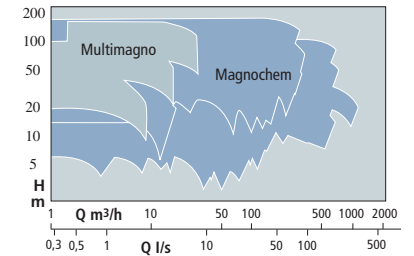
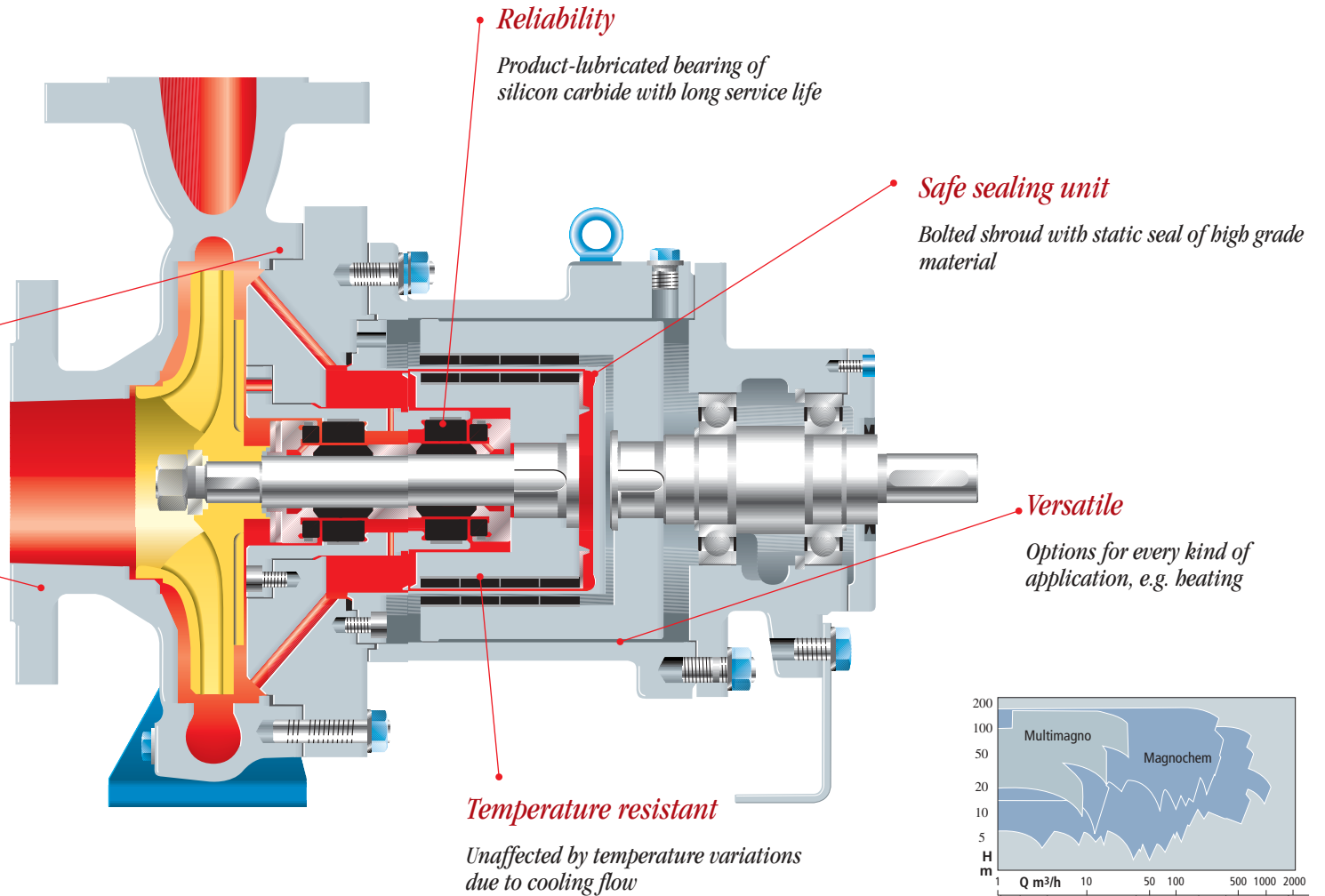

## The conversion of CPK to Magnochem.

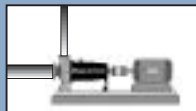
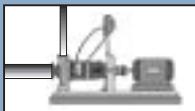

## The range of the Magnochem

Q:	up to 1200 m <sup>3</sup> /h	Material:
H:	up to 150 m	EN-JS 1025 (GGG 40.3),
t:	-40 to +300 °C	GP240GH+N (GS-C25N),
p:	PN 16, PN 25	1.4408, 9.4460, specialist materials

## The range of the Multimagno

Q:	up to 30 m <sup>3</sup> /h	Material:
H:	up to 150 m	EN-JS 1025 (GGG 40.3)
t:	-40 to +250 °C	1.4408
p:	PN 25	

## Less is more.

KSB's magnetic coupling offers you constructive advantages.

Due to its high quality shroud in 2.4610, the eddy current losses are minimised, as are the friction losses due to the design of the inner rotor. The resulting energy savings as well as the leakage-free operation constitute an active contribution to environmental protection.

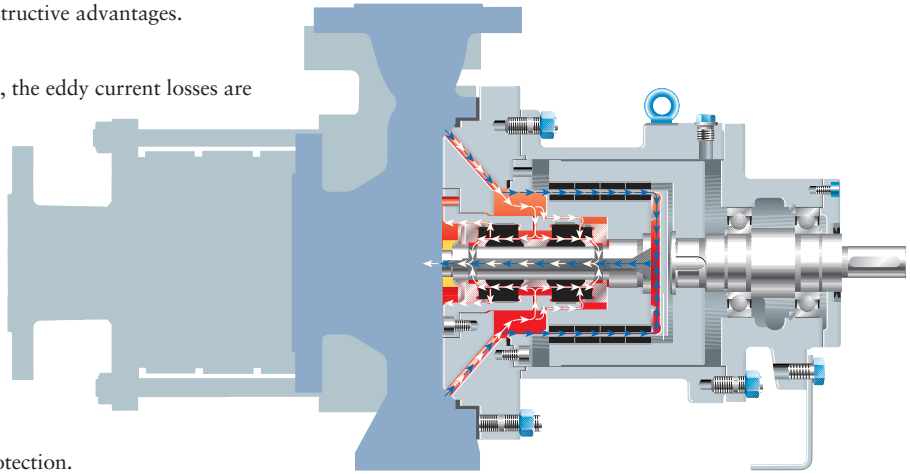

## Persuasive inner warmth.

A shorter warm-up time is achieved by the heating device integrated in the shroud, which also has a lower heat requirement than an external heating unit. The integrated heat exchanger only heats where needed, i.e. directly in the area of the shroud. Its efficiency is used to full advantage as no air gap prevents heat transfer. Considerable savings in energy and cost are the result.

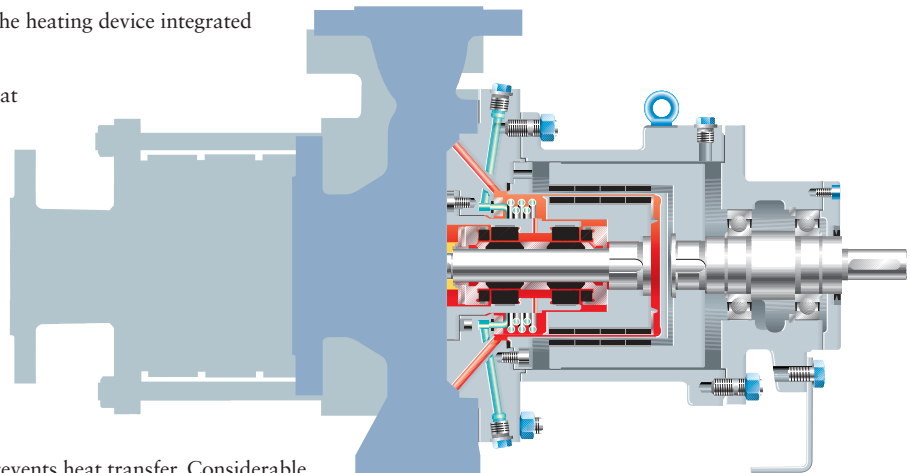

Multimagno

Magnochem