

IN A TIGHT CORNER? THINK ETASECO!





Etaseco



In those critical moments, you need to hold tight. Etaseco helps you keep things under control. This pump combines the tried and tested Eta hydraulics with a robust canned motor. Absolutely safe and reliable transport of critical media such as alkaline solutions, oils, coolants or hot water is therefore no problem for Etaseco.

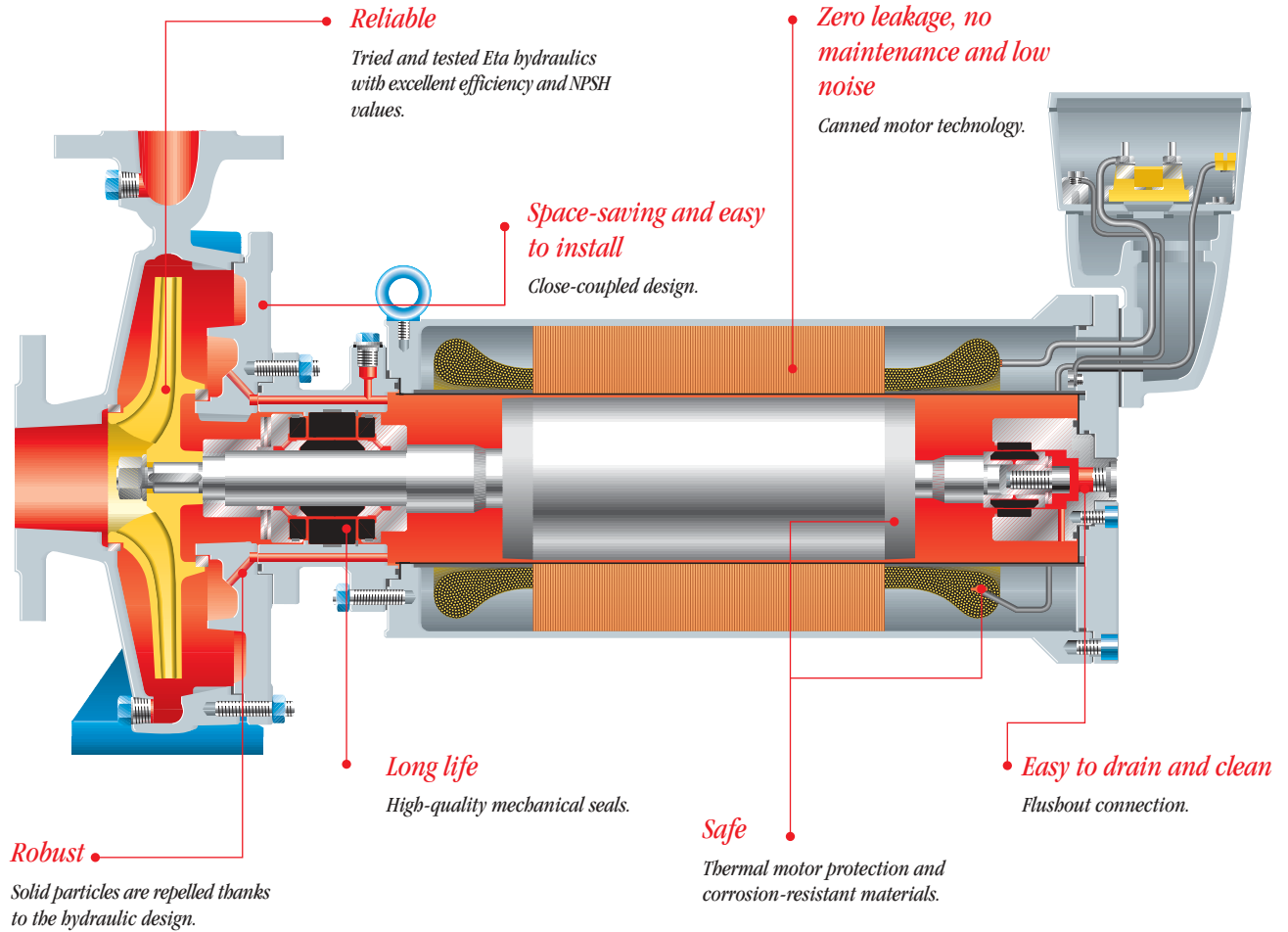

Etaseco values

Pump sizes:	32-80
Flow rate:	up to 260 m ³ /h
Total head:	up to 100 m
Temperature:	-40°C to +140°C
Pump discharge pressure:	up to 16 bar

